

DANGER!



Potentially hazardous voltages are present. Electrical shock can cause death or serious injury. Installation should be done by qualified personnel following all National, State & Local Codes.



Présence de tensions potentiellement dangereuses. Une décharge électrique peut causer la mort ou des blessures graves. L'installation devrait être effectuée par du personnel qualifié suivant tous les codes nationaux, provinciaux et locaux.

BE SURE TO REMOVE ALL POWER SUPPLYING THIS EQUIPMENT BEFORE CONNECTING OR DISCONNECTING WIRING. READ INSTRUCTIONS BEFORE INSTALLING OR OPERATING THIS DEVICE. KEEP FOR FUTURE REFERENCE.

S'ASSURER DE SUPPRIMER TOUTE ALIMENTATION ÉLECTRIQUE DE CET ÉQUIPEMENT AVANT DE BRANCHER OU DE DÉBRANCHER LES CÂBLAGES.

Installation & Wiring

Mount the appropriate 11 pin octal socket (such as the Macromatic 70170-D or Custom Connector OT11-PC) in a suitable enclosure. When making connections to the socket, make sure to match the terminal numbers on the socket to the ones shown on the wiring diagram (the wiring diagram on the relay is the view looking towards the bottom of the relay vs. the top of the socket). Use one or two #12-22 solid or stranded copper or copper-clad aluminum conductors with terminals on Macromatic or Custom Connector sockets - a terminal tightening torque of 12 in-lbs should be used. See Product Setup on reverse side.

CAP Series relays have three built-in current ranges (see below) to monitor both AC & DC current. Each one is easily selectable by connecting to the corresponding terminal and also to the COM terminal (see Wiring Diagram below). For example, to select a range of 0.05 – 1A DC, connect the monitored current wires to Pins 6 & 8:

Review Operation and Function Charts on reverse side.

Troubleshooting

If the unit fails to operate properly, check that all connections are correct per the appropriate wiring diagram on the product. If problems continue, contact Macromatic at 800-238-7474 or e-mail tech-support@macromatic.com for assistance.

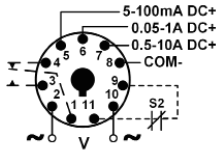
DC	AC	Pin #	Wiring
5 – 100mA	3.5 – 70.7mA	5	
0.05 – 1A	0.035 – 0.707A	6	
0.5 – 10A	0.35 – 7.07A	7	

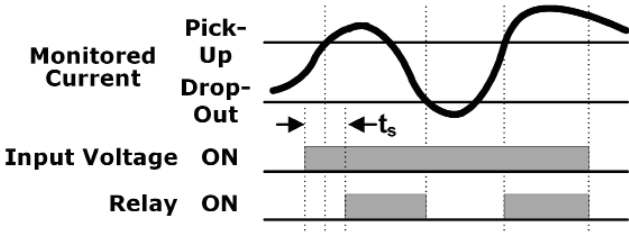
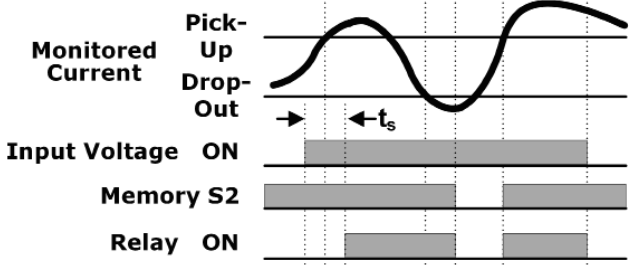
Operation	Function Chart
<p>Non-Latching:</p> <p>The unit will operate in the non-latching mode if no circuit is completed across pins 9 & 11. After input voltage is applied (LED is Green) & the sensing delay (t_s) of 0.1 – 10 seconds is completed, the relay will energize when the monitored current is above the adjustable pick-up setting and the LED will be Red. It will de-energize when the monitored AC current is below the adjustable drop-out setting (50-95% of the selected pick-up setting) or when input power is removed. The LED will be Green.</p>	 <p>The chart shows a sinusoidal wave for Monitored Current. Two horizontal lines represent the Pick-Up and Drop-Out current levels. A shaded bar for Input Voltage is ON during the first and third cycles. The Relay ON state is shown as shaded bars that occur only when the current is above the pick-up level and the input voltage is present. A sensing delay t_s is indicated between the start of input voltage and the start of the relay energization.</p>
<p>Latching:</p> <p>The unit will operate in the latching mode if a N.C. contact (Memory S2) is connected across pins 9 & 11 (see Wiring Diagram). After input voltage is applied (LED is Green) & the sensing delay (t_s) of 0.1 – 10 seconds is completed, the relay will energize when the monitored current is above the adjustable pick-up setting and the LED will be Red. It will de-energize only when the monitored AC current is below the drop-out setting and the N.C. contact (Memory S2) is opened or when input voltage is removed. The LED will be Green. It is recommended to set the hysteresis at 5% when in the latching mode.</p>	 <p>The chart is similar to the Non-Latching mode but includes a Memory S2 signal. The Memory S2 signal is a shaded bar that is ON during the first and third cycles, even when the input voltage is removed. The Relay ON state is shown as shaded bars that occur when the current is above the pick-up level and either the input voltage or the Memory S2 signal is present.</p>

Warranty

All catalog-listed CAP Series Relays manufactured by Macromatic are warranted to be free from defects in workmanship or material under normal service and use for a period of five (5) years from date of manufacture.