

Modular Style Time Delay Relays



FEATURES

- 10 Functions
- Broad Timing Range (from 0.1 sec to 10 days)
- Contact Configuration
- Universal Power Supply
- 2 LED Status Indicators
- Only 17.5 mm Wide
- DIN Rail Mountable
- RoHS Compliant

BENEFITS

- 5 Timing Functions Controlled via control
- 4 Timing Functions Controlled via Trigger Input
- 1 Timing Function of Memory Latching Relay
- Meets Most Timing Requirements
- SPDT or DPDT
- 12 to 240 VAC/VDC
- Indicates Coil Status at a Glance
- Ideal for Tight Spaces
- Easy Installation / No Tools
- Environmentally Friendly



This device is designed for connection of 1-phase voltage, 12-240 V AC/DC and must be installed according to norms valid in existing state. Connections must be made according to details in this instruction sheet. Installation, connections, setting and servicing should be performed by qualified electrician staff, who understands this instruction sheet and functions of respective device.

Before starting installation ensure that the main switch is in "OFF" position and there should be no power going to the device. Qualified installer must also ensure the device is being installed into a temperature controlled environment which will guarantee not to exceed the specified maximum operating temperature. For installation use a screwdriver with 2 mm tip.

DESCRIPTION

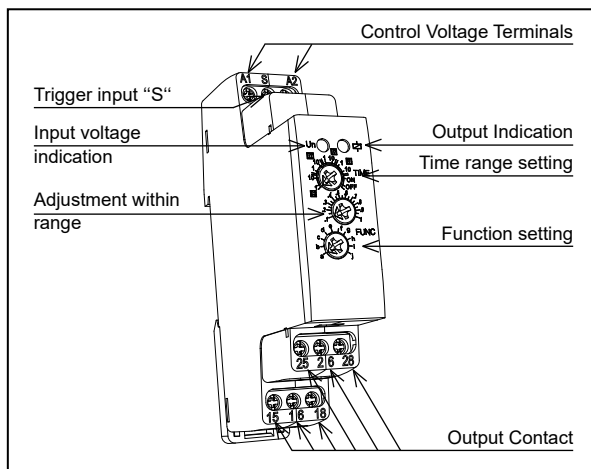

TIME RANGES

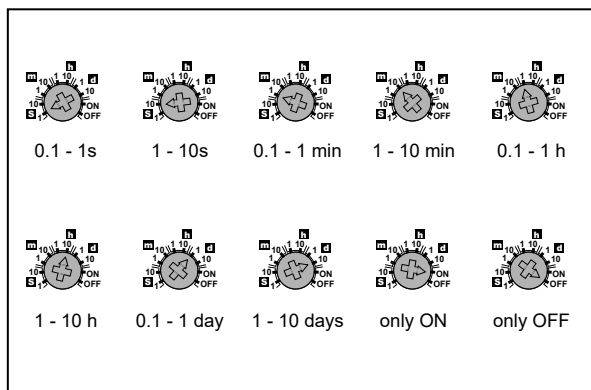

WIRING DIAGRAMS

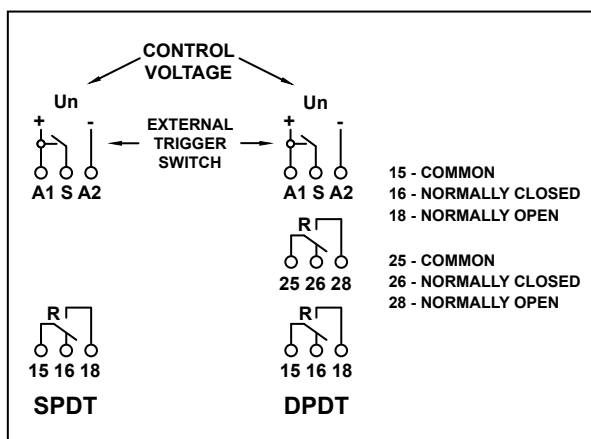

Function	Operation	Timing Chart
A. ON DELAY Power On	When the control voltage U is applied, timing delay t begins. Relay contacts R change state after time delay is complete. Contacts R return to their shelf state when control voltage U is removed. Trigger switch is not used in this function.	
B. FLASHER Starting Off	When controls voltage U is applied, time delay t begins. When time delay t is complete, relay contacts R change state for time delay t. This cycle will repeat until control voltage U is removed. Trigger switch is not used in this function.	
C. INTERVAL Power On	When controls voltage U is applied, relay contacts R change state immediately and timing cycle begins. When time delay is complete, contacts return to their shelf state. When control voltage U is removed, contacts will also return to their shelf state. Trigger switch is not used in this function.	
D. OFF DELAY S Break	Controls voltage U must be applied continuously. When trigger S is closed, relay contacts R change state. When trigger S is opened, delay t begins. When delay t is complete, contacts R return to their shelf state. If trigger S is closed before time delay t is complete, then time is reset. When trigger S is opened, the delay begins again, and relay contacts remain in their energized state. If control voltage U is removed, relay contacts R return to their shelf state.	
E. RETRIGGERABLE ONE SHOT	Upon application of control voltage U, the relay is ready to accept trigger signal S. Upon application of the trigger signal S, the relay contacts R transfer and the preset time t begins. At the end of the preset time t, the relay contacts R return to their normal condition unless the trigger signal S is opened and closed prior to time out t (before preset time elapses). Continuous cycling of the trigger signal S at a rate faster than the preset time will cause the relay contacts R to remain closed. If control voltage U is removed, relay contacts R return to their shelf state.	
F. FLASHER Starting On	When control voltage U is applied, relay contacts R change state immediately and time delay t begins. When time delay t is complete, contacts return to their shelf state for time delay t. This cycle will repeat until control voltage U is removed. Trigger switch is not used in this function.	
G. PULSE GENERATOR	Upon application of control voltage U, a single output pulse of 0.5 seconds is delivered to relay after time delay t. Power must be removed and reapplied to repeat pulse. Trigger switch S is not used in this function.	
H. ONE SHOT	Upon application of control voltage U, the relay is ready to accept trigger signal S. Upon application of the trigger signal S, the relay contacts R transfer and the preset time t begins. During time-out, the trigger signal S is ignored. The relay resets by applying the trigger signal S when the relay is not energized.	
I. ON/OFF DELAY S Make/Break	Control voltage U must be applied continuously. When trigger S is closed, time delay t begins. When time delay t is complete, relay contacts R change state and remain transferred until trigger S is opened. If control voltage U is removed, relay contacts R return to their shelf state.	
J. MEMORY LATCH S Make	Control voltage U must be applied continuously. Output changes state with every trigger S closure. If control voltage U is removed, relay contacts R return to their shelf state.	

Modular Style Time Delay Relays



SPECIFICATIONS

OUTPUT CHARACTERISTICS		
Number and type of contacts	SPDT or DPDT	
Contact material	Silver alloy	
Merge	15 A @ 240 VAC, 240 V 50/60 Hz	
Contact Ratings	1/3 HP @ 120 V 50/60 Hz	
	3/4 HP @ 240 V 50/60 Hz	
	B300 pilot duty	
Minimum switching requirement	100 mA	
Indication	Red LED	
INPUT CHARACTERISTICS		
Control voltage range	12 to 240 V 50/60 Hz/ VDC	
Operating range (% of nominal)	85% to 110%	
Maximum consumption	3 VA (AC)	
	1.7 W (DC)	
Indication	Green LED	
TIMING CHARACTERISTICS		
Functions available	10	
Time scales	10	
Time ranges	0.1 sec to 10 days	
Tolerance (mechanical setting)	5%	
Repeatability (constant voltage and temperature)	0.2%	
Reset time (maximum)	150 ms	
Trigger pulse length (minimum)	50 ms	
PERFORMANCE CHARACTERISTICS		
Electrical life (operations @ rated current)	100,000 cycles (resistive)	
Mechanical life (unpowered)	10,000,000 cycles	
Dielectric strength	Input to contacts	2500 VAC
	Between open contacts	1000 VAC
Terminal wire capacity	12-22 AWG	
Terminal torque (maximum)	3.5 in-lbs lbf in (0.4 Nm)	
ENVIRONMENT		
Product certifications	cULus, CE, RoHS	
Ambient air temperature	Storage	-30 to +70 °C (-22 to +158 °F)
Around the device	Operation	-20 to +55 °C (-4 to +131 °F)
Degree of protection		IP 20
Weight		65 grams (2.3 oz)

DIMENSIONS INCHES (MILLIMETERS)

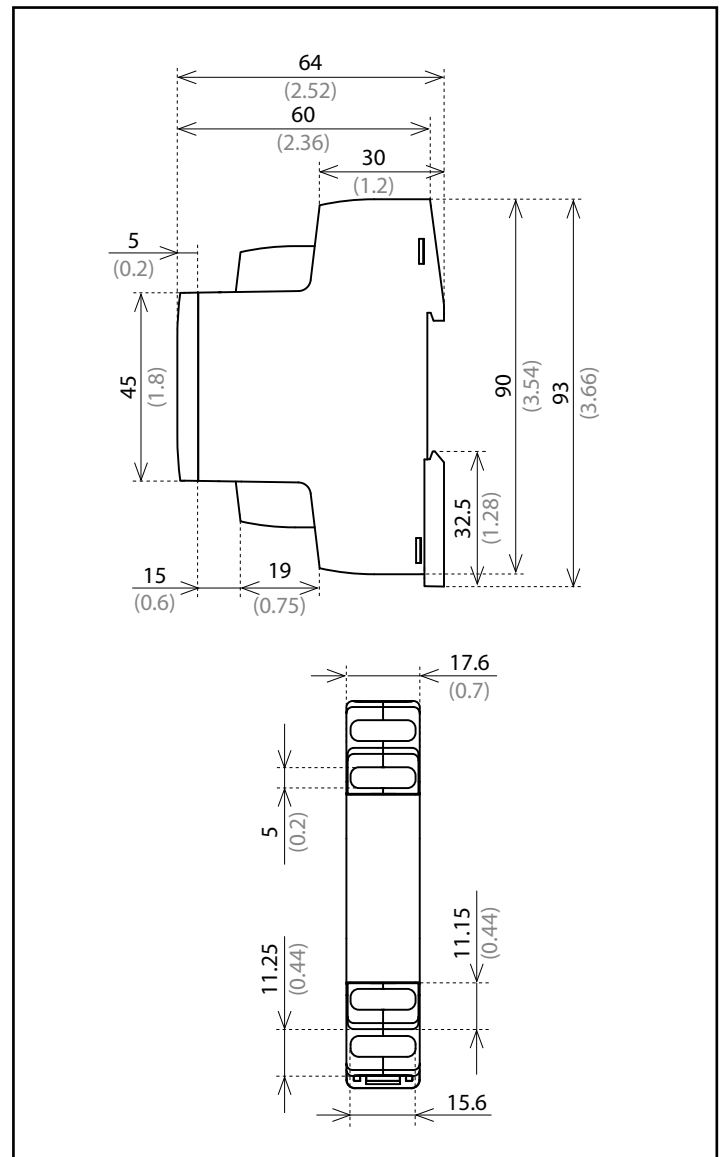

RELAY CONTACT 15 A	LOAD								
						AC1A	C3	AC15	DC1 (24/110/220 V)
AgNi	1000 W			70µF		4000 VA	0.9 kW	750 VA	15 A/0.5 A/0.35 A